

## 포지셔닝 부싱, 스틸 소재, 센터링 유닛용

품목 설명/제품 이미지



### 설명

**재질:**  
스틸.

**표면 마무리:**  
경화 및 연마 처리.

**정보:**  
포지셔닝 테이퍼에 적합한 포지셔닝 부싱.

**온도 범위:**  
최대 +80 °C.

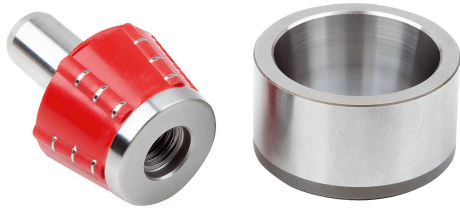

## 포지셔닝 부싱, 스틸 소재, 센터링 유닛용

품목 설명/제품 이미지

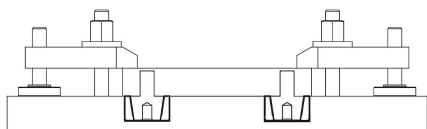
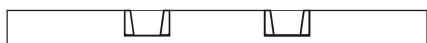
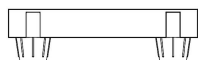

## 포지셔닝 부싱, 스틸 소재, 센터링 유닛용

도면

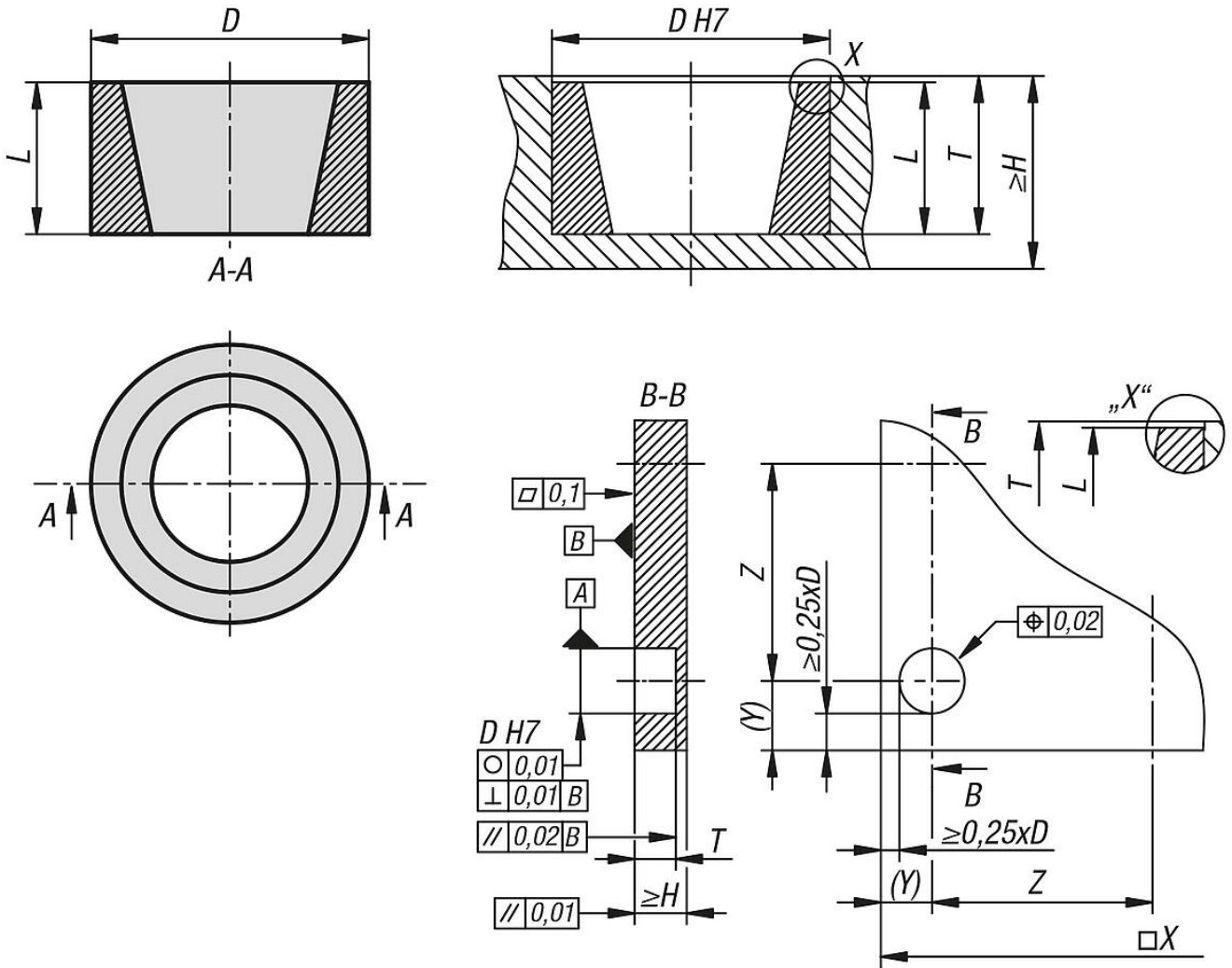

### 품목 요약

### 센터링 유닛

주문 번호	크기	D	H min.	L max.	T	품목 번호용
K1628.1	1	16	12,5	8,5	9-0,1	K1627.1
K1628.3	3	32	25	17,5	18-0,1	K1627.3