

## 스페이서 링 스테인레스 스틸

품목 설명/제품 이미지



**설명**

**재질:**

스테인리스 스틸 1.4305 또는 1.4404.

**표면 마무리:**

광택 처리.

**정보:**

스페이서 링을 사용함으로 인덱스 플런저 길이를 조절할 수 있습니다.(벽 두께)

**도면 설명:**

- 1) 잠금 나사
- 2) 스페이서 링

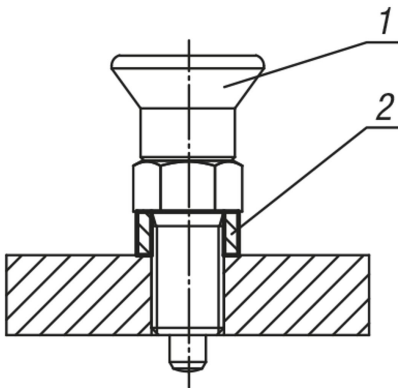

**도면**

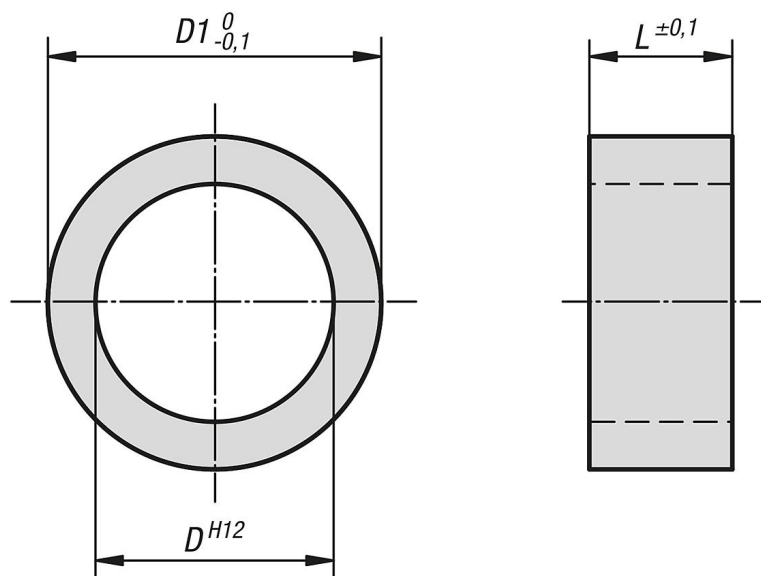

## 스페이서 링 스테인레스 스틸

## 품목 요약

주문 번호	스틸 키	D	D1	L
K0665.90811021	1.4305	8	11	2
K0665.90811031	1.4305	8	11	3
K0665.90811041	1.4305	8	11	4
K0665.90811061	1.4305	8	11	6
K0665.90811081	1.4305	8	11	8
K0665.91014021	1.4305	10	14	2
K0665.91014031	1.4305	10	14	3
K0665.91014041	1.4305	10	14	4
K0665.91014061	1.4305	10	14	6
K0665.91014081	1.4305	10	14	8
K0665.91215021	1.4305	12	15	2
K0665.91215041	1.4305	12	15	4
K0665.91215051	1.4305	12	15	5
K0665.91215061	1.4305	12	15	6
K0665.91215081	1.4305	12	15	8
K0665.91217021	1.4305	12	17	2
K0665.91217041	1.4305	12	17	4
K0665.91217051	1.4305	12	17	5
K0665.91217061	1.4305	12	17	6
K0665.91217081	1.4305	12	17	8
K0665.91621041	1.4305	16	21	4
K0665.91621051	1.4305	16	21	5
K0665.91621061	1.4305	16	21	6
K0665.91621081	1.4305	16	21	8
K0665.91621101	1.4305	16	21	10
K0665.90811022	1.4404	8	11	2
K0665.90811032	1.4404	8	11	3
K0665.90811042	1.4404	8	11	4
K0665.90811062	1.4404	8	11	6
K0665.90811082	1.4404	8	11	8
K0665.91014022	1.4404	10	14	2
K0665.91014032	1.4404	10	14	3
K0665.91014042	1.4404	10	14	4
K0665.91014062	1.4404	10	14	6
K0665.91014082	1.4404	10	14	8
K0665.91215022	1.4404	12	15	2
K0665.91215042	1.4404	12	15	4
K0665.91215052	1.4404	12	15	5
K0665.91215062	1.4404	12	15	6
K0665.91215082	1.4404	12	15	8
K0665.91217022	1.4404	12	17	2
K0665.91217042	1.4404	12	17	4
K0665.91217052	1.4404	12	17	5
K0665.91217062	1.4404	12	17	6
K0665.91217082	1.4404	12	17	8
K0665.91621042	1.4404	16	21	4
K0665.91621052	1.4404	16	21	5
K0665.91621062	1.4404	16	21	6
K0665.91621082	1.4404	16	21	8
K0665.91621102	1.4404	16	21	10